

X2-10GB-LX4-PRO

Cisco® X2-10GB-LX4 Compatible TAA Compliant 10GBase-LX4 X2 Transceiver (MMF, 1310nm, 300m, 0 to 70C, SC)

Features

- X2 MSA 2.0 Compliance
- Duplex SC Connector
- Commercial Temperature 0 to 70 Celsius
- Multi-mode Fiber
- Hot Pluggable
- Excellent ESD Protection
- Metal with Lower EMI
- RoHS Compliant and Lead Free



Applications:

- 10GBase Ethernet
- Access and Enterprise

Product Description

This Cisco® X2-10GB-LX4 compatible X2 transceiver provides 10GBase-LX4 throughput up to 300m over multi-mode fiber (MMF) using a wavelength of 1310nm via a SC connector. It is guaranteed to be 100% compatible with the equivalent Cisco® transceiver. This easy to install, hot swappable transceiver has been programmed, uniquely serialized and data-traffic and application tested to ensure that it will initialize and perform identically. It is built to meet or exceed the specifications of Cisco®, as well as to comply with MSA (Multi-Source Agreement) standards to ensure seamless network integration. This transceiver is Trade Agreements Act (TAA) compliant. We stand behind the quality of our products and proudly offer a limited lifetime warranty.

Proline's transceivers are RoHS compliant and lead-free.

TAA refers to the Trade Agreements Act (19 U.S.C. & 2501-2581), which is intended to foster fair and open international trade. TAA requires that the U.S. Government may acquire only "U.S. – made or designated country end products.



Absolute Maximum Ratings

Parameter	Symbol	Min.	Typ.	Max.	Unit
Storage Ambient Temperature	T _S	-40		85	°C
Supply Voltage (3.3V)	V ₃	0		4	V
Supply Voltage (APS)	V _{APS}	0		1.5	V
Optical Receiver Input	P _{IMAX}			1	dBm

General Specifications

Parameter	Symbol	Min.	Typ.	Max.	Unit
Data Rate	DR		10.3125		GBd
Bit Error Rate	BER			10 ⁻¹²	
Total Power Consumption	P			2.2	W
Supply Voltage (+3.3V)	V _{CC3}	3.14	3.3	3.47	V
Supply Voltage (APS)	V _{CCAPS}	1.152	1.2	1.248	V
Supply Current (+3.3V)	I _{CC3}			300	mA
Supply Current (APS)	I _{CCAPS}			1000	mA
Case Operating Temperature	T _C	0		70	°C

Link Distance

Parameter	Fiber Type	Modal Bandwidth@ 850nm (MHz-km)	Distance Range (m)
10.3 GBd	62.5/125μm MMF	160	2-26
	62.5/125μm MMF	200	2-33
	50/125μm MMF	400	2-66
	50/125μm MMF	500	2-82
	50/125μm MMF	2000	2-300

Electrical Characteristics - DC

Parameter	Symbol	Min.	Typ.	Max.	Unit	Notes
A. 1.2V COMS I/O DC Characteristics (PRTAD; LASI; RESET; TX_ON/OFF)						
External Pull-Up Resistor for Open Drain	R_{PU}	10		22	$K\Omega$	
Output High Voltage	V_{OH}	1			V	
Output Low Voltage	V_{OL}			0.15	V	
Input High Voltage	V_{IH}	0.84		1.2	V	
Input Low Voltage	V_{IL}			0.36	V	
Input Pull-Down Current	IPD	20	120	120	μA	$V_{IN}=1.2V$
B. XAUI I/O DC Characteristics (TXLAN[0..3]; RXLANE[0..3])						
Differential Input Amplitude (pk-pk)	V_{IN_XAUI}	200		1600	mV	AC Coupled
Differential output Amplitude (pk-pk)	V_{OUT_XAUI}	800		1600	mV	AC Coupled
C. MDIO I/O DC Characteristics (MDIO; MDC)						
Output Low Voltage	V_{OL}			0.2	V	$I_{OL} = 100\mu A$
Output Low Current	I_{OL}			4	mA	
Input High Voltage	V_{IH}	0.84		1.2	V	
Input Low Voltage	V_{IL}			0.36	V	
Pull-Up Supply Voltage	V_{PU}		1.2		V	
Input Capacitance	C_{IN}			10	pF	
Load Capacitance	C_{LOAD}			470	pF	
External Pull-Up Resistance	RPU	200			Ω	

Electrical Characteristics - AC

Parameter	Symbol	Min.	Typ.	Max.	Unit	Notes
A. XAUI Input AC Characteristics (TXLANE[0..3])						
Baud Rate	BR _{XAUI_IN}		3.125		GBd	
Baud Rate Tolerance	BR _{TOL_XAUI}	-100		100	ppm	
Differential Input Impedance	Z _{IN_XAUI}		100		Ω	
Differential Return Loss	RL _{IN}	10			dB	100MHz to 2.5 GHz
Input Differential Skew	T _{IN_SKEW}			75	ps	Crossing Point
Jitter Amplitude Tolerance	J _{XAUI_TOL}			0.65	UI _{pp}	IEEE 802.3ae
B. XAUI Output AC Characteristics (RXLANE[0..3])						
Baud Rate	BR _{XAUI_OUT}		3.125		GBd	
Baud Rate Variation	BR _{XAUI_VAR}	-100		100	ppm	
XAUI Eye Mask (far-end)		According to IEEE 802.3ae				
Output Differential Skew	T _{OUT_SKEW}			15	ps	
Output Differential Impedance	Z _{OUT_XAUI}		100		Ω	DC
Differential Output Return Loss	RL _{OUT}	10			dB	100 MHz to 2.5 GHz
Total Jitter	TJ _{XAUI}			0.35	UI	Near-end No pre-equalization 1 UI=320 ps
Deterministic Jitter	DJ _{XAUI}			0.17	UI	
C. Power-On Reset Characteristics						
Power-On Reset and TX_ONOFF Characteristics		According to X2 MSA Issue				
D. MDIO I/O AC Characteristics (MDIO; MDC)						
MDIO Data Hold Time	T _{HOLD}	10			ns	
MDIO Data Setup Time	T _{SU}	10			ns	
Delay from MDC Rising Edge to MDIO Data Change	T _{DELAY}			300	ns	
MDC Clock Rate	f _{MAX}			2.5	MHz	

Optical Characteristics

Parameter	Symbol	Min.	Typ.	Max.	Unit	Notes
Transmitter						
Optical Wavelength	λ	840	850	860	nm	
Launch Power	P_{OUT}	-7.3		-1.3	dBm	
Launch Power in OMA	P_{OUT_OMA}	-4.3		-2.8	dBm	
Launch Power of OFF Transmitter	P_{OUT_OFF}			-30	dBm	
Side Mode Suppression Ratio	SMSR	30			dB	
Spectral Width (RMS)	$\Delta \lambda$			0.45	nm	
Optical Extinction Ratio	ER	3			dB	
Optical Modulation amplitude	OMA	525			μ W	
Optical Return Loss Tolerance	ORL_T			12	dB	
Relative Intensity Noise	RIN			-128	dB/Hz	
Transmitter Dispersion Penalty	TDP			3.9	dB	
Eye Mask Definition		According to IEE 802.3ae and 10Gbase-SR				
Receiver						
Center Wavelength Range	λ_C	840		860	nm	
Optical Input Power	P_{IN}	-9.9		-1	dBm	
Receiver Sensitivity in OMA	P_{IN_OMA}			-11.1	dBm	
Stressed Receiver Sensitivity	P_{IN_S}			-7.5	dBm	
Receiver Reflectance	TR_{RX}			-12	dB	
Receiver electrical 3dB upper cutoff frequency	FR			12.3	GHz	

Pin Descriptions

Pin#	Symbol	I/O	Logic	Description	Pin#
1	GND	I	Supply	Electrical ground	1
2	GND	I	Supply	Electrical ground	2
3	GND	I	Supply	Electrical ground	3
4	5.0V	I	Supply	Power	4
5	3.3V	I	Supply	Power	5
6	3.3V	I	Supply	Power	6
7	APS	I	Supply	Adaptive Power Supply	7
8	APS	I	Supply	Adaptive Power Supply	8
9	LASI	O	Open Drain	Link Alarm Status Interrupt. 10-22k ohm pull up on host	9
10	REST	I	1.2V CMOS	TX OFF when MDIO RESET	10
11	VEND SPECIFIC			Vendor Specific Pin. Leave unconnected	11
12	TX ON/OFF	I	1.2V CMOS	Transmitter ON/OFF	12
13	Reserved			Reserved	13
14	MOD DETECT	O		Pulled low inside module through 1k ohm	14
15	VEND SPECIFIC			Vendor Specific Pin. Leave unconnected	15
16	VEND SPECIFIC			Vender Specific Pin. Leave unconnected	16
17	MDIO	I/O	Open Drain	Management Data IO	17
18	MDC	I	1.2V CMOS	Management data clock	18
19	PRTAD4	I	1.2V CMOS	Port Address bit 4 (Low=0)	19
20	PRTAD3	I	1.2V CMOS	Port Address bit 3 (Low=0)	20
21	PRTAD2	I	1.2V CMOS	Port Address bit 2 (Low=0)	21
22	PRTAD1	I	1.2V CMOS	Port Address bit 1 (Low=0)	22
23	PRTAD0	I	1.2V CMOS	Port Address bit 0 (Low=0)	23
24	VEND SPECIFIC			Vendor Specific Pin. Leave unconnected	24
25	APS SET	O		Feedback output for APS	25
26	RESERVED			Reserved for Avalanche Photodiode use	26
27	APS SENSE	O	Analog	APS Sense Connection	27
28	APS	I	Supply	Adaptive Power Supply	28
29	APS	I	Supply	Adaptive Power Supply	29
30	3.3V	I	Supply	Power	30
31	3.3V	I	Supply	Power	31
32	5.0V		Supply	Power	32
33	GND	I	Supply	Electrical Ground	33
34	GND	I	Supply	Electrical Ground	34
35	GND	I	Supply	Electrical Ground	35
36	GND	I	Supply	Electrical Ground	36
37	GND	I	Supply	Electrical Ground	37
38	RESERVED			Reserved	38

39	RESERVED			Reserved	39
40	GND	I	Supply	Electrical ground	40
41	RX LANE 0+	O	AC	Module XAUI Output Lane 0+	41
42	RX LANE 0-	O	AC	Module XAUI Output Lane 0-	42
43	GND	I	Supply	Electrical ground	43
44	RX LANE 1+	O	AC	Module XAUI Output Lane 1+	44
45	RX LANE 1-	O	AC	Module XAUI Output Lane 1-	45
46	GND	I	Supply	Electrical ground	46
47	RX LANE 2+	O	AC	Module XAUI Output Lane 2+	47
48	RX LANE 2-	O	AC	Module XAUI Output Lane 2-	48
49	GND	I	Supply	Electrical ground	49
50	RX LANE 3+	O	AC	Module XAUI Output Lane 3+	50
51	RX LANE 3-	O	AC	Module XAUI Output Lane 3-	51
52	GND	I	Supply	Electrical ground	52
53	GND	I	Supply	Electrical ground	53
54	GND	I	Supply	Electrical ground	54
55	TX LANE 0+	O	AC	Module XAUI Input Lane 0+	55
56	TX LANE 0-	O	AC	Module XAUI Input Lane 0-	56
57	GND	I	Supply	Electrical ground	57
58	TX LANE 1+	O	AC	Module XAUI Input Lane 1+	58
59	TX LANE 1-	O	AC	Module XAUI Input Lane 1-	59
60	GND	I	Supply	Electrical ground	60
61	TX LANE 2+	O	AC	Module XAUI Input Lane 2+	61
62	TX LANE 2-	O	AC	Module XAUI Input Lane 2-	62
63	GND	I	Supply	Electrical ground	63
64	TX LANE 3+	O	AC	Module XAUI Input Lane 3+	64
65	TX LANE 3-	O	AC	Module XAUI Input Lane 3-	65
66	GND	I	Supply	Electrical ground	66
67	RESERVED			Reserved	67
68	RESERVED			Reserved	68
69	GND	I	Supply	Electrical Ground	69
70	GND	I	Supply	Electrical Ground	70

Electrical Pad Layout

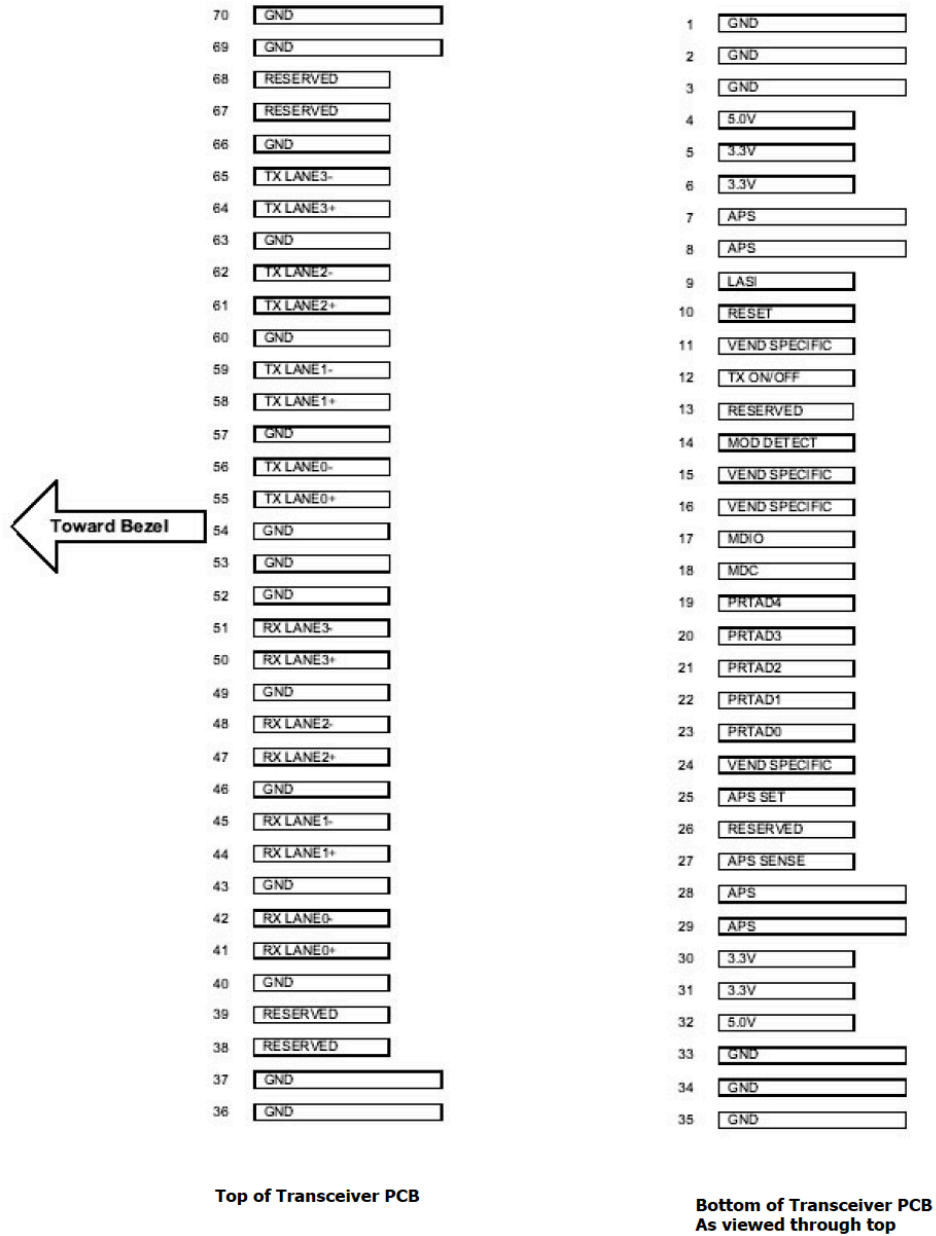

Digital Diagnostic

Parameter	Symbol	Min.	Typ.	Max.	Unit	Notes
Temperature Monitor	T _{MON}	-5		5	°C	
Laser Bias Monitor	I _{MON}	-10		10	%	
TX Power Monitor	P _{TX}	-3		3	dBm	
RX Power Monitor	P _{RX}	-3		3	dBm	

Mechanical Specifications

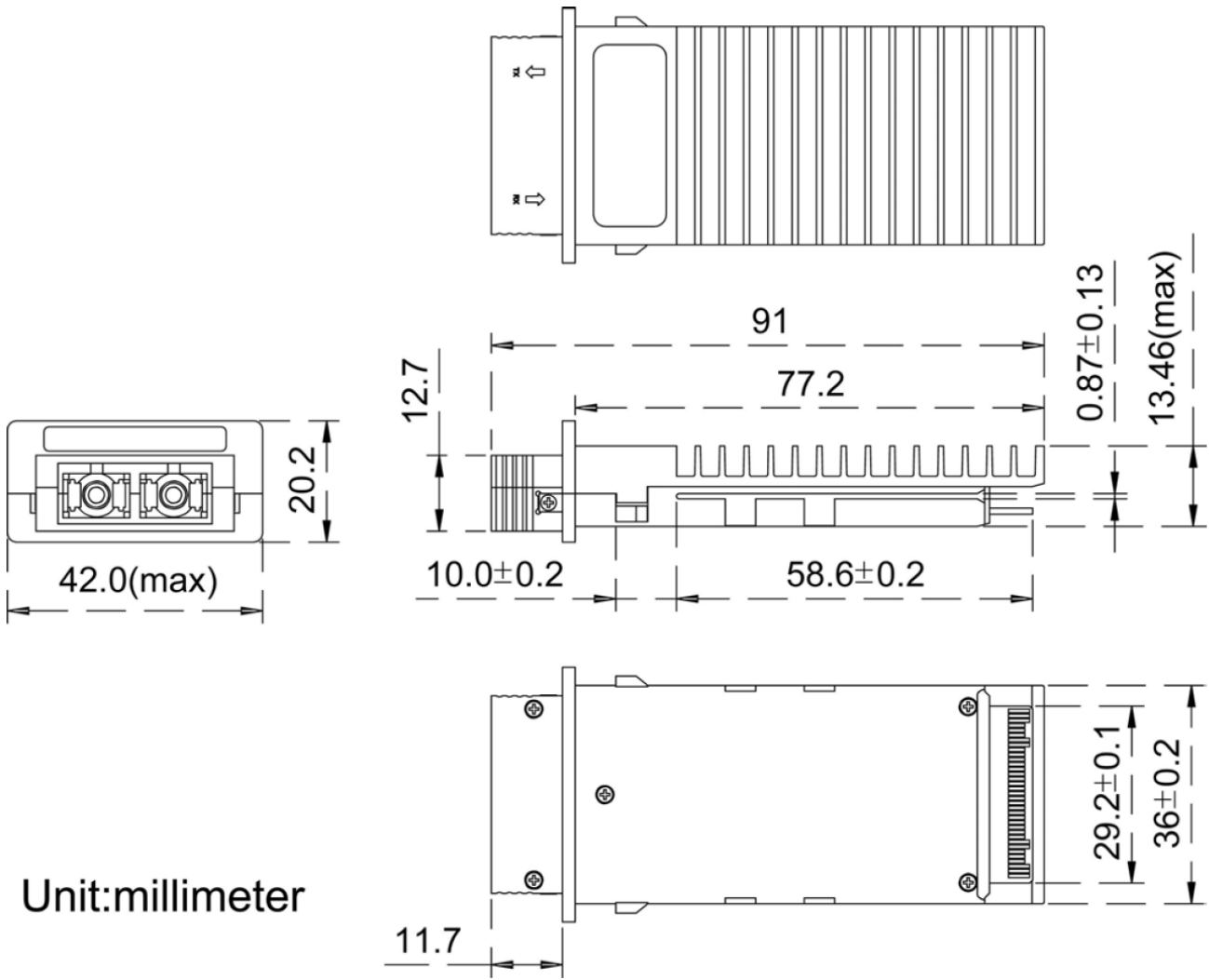

Unit: millimeter

About Us:

Proline Options is one of North America's leading providers of transceivers and high speed cabling. With a reputation for quality, tested products that cover the connectivity spectrum, Proline Options has a solution for you regardless of the specification.

At Proline Options, every product is tested in its intended application - never batch or spec tested only. We run bandwidth, distance and IOS network tests. We have documented an impressive 0.03% failure rate over the last 10 years. To continue this rate of success we invest millions annually in our own on-site testing lab.



Tel: 855.933.3223

Email: sales@prolineoptions.com

Email: techsupport@prolineoptions.com

Web: <https://www.prolineoptions.com>